

# Analysis and Integration of Renewable Energy Resources Based Microgrid Using Smart Inverter

Sughand Mallah, Aisha Aftab, Amjad Hussain Memon

Mehran University of Engineering and Technology Jamshoro, Pakistan  
sughand1mallah@gmail.com, aaishaaftab1@gmail.com, ahm13043@gmail.com

## Abstract

Nowadays the world is depending on renewable energies like solar energy and wind energy as they are the natural resources to generate power. By combining both the renewable energies, it produces a system named as solar wind hybrid system as solar and wind energy are tremendous in nature and together they increase the reliability of the system. In this research paper, solar energy and wind turbine are used as the main sources, along with solar panel a buck boost converter is used to maintain the voltage to a rated value and with the wind turbine a rectifier circuit is used to convert AC voltage into DC. The characteristics of RES with an AC grid are also observed using solar and wind energy. With the aid of a multi-level inverter, solar and wind energy are converted from DC to AC at a predetermined voltage in order to produce electricity. It can be stated that, in comparison to traditional energy sources, renewable energy sources are currently quite useful.

**Index Terms**— hybrid system, perturb and observe, solar panel, cascaded multilevel inverter, wind turbine.

## I. INTRODUCTION

Solar energy is one of the most notable forms of renewable energy because it is clean, cost-free, and ecologically good. Undoubtedly, there are a number of solar energy technologies that necessitate research [1-3]. In order to maximize the advantages of solar radiation, integrating solar energy systems is currently popular. Solar thermal collectors and solar photovoltaic are combined to create a photovoltaic/thermal (PVT) hybrid solar system, which allows for the simultaneous production of heat and electricity [4-7]. On the other hand, because of their consistency, availability from nature, and rich and pure features, renewable energy sources are the most efficient alternative energy sources [8-11]. Due to this, integrating a variety of renewable energy sources enables the

production of more steady and secure power. In order to overcome the drawbacks of an individual renewable energy source's unpredictability and randomness, hybrid solar and wind systems are deployed [12, 13]. Different renewable energy sources are combined in the form of a microgrid to make a hybrid system [14-16]. Figure 1 shows the basic layout of a microgrid [17].

## II. METHODOLOGY

This simulation model is built on combining renewable energy sources like sun and wind to produce electrical energy. To create a dependable hybrid system, solar and wind energy resources are used. Solar array is commonly used nowadays to generate electricity. A pv array module is used to generate dc voltage. Using a buck-boost converter and MPPT unit, a solar panel is used to produce a DC voltage of 24 volts for solar energy. Maximum power point tracking is a method to produce highest power from PV panels.

This method uses the perturb and observe (PO) algorithm to maximize power. Nowadays wind energy is used along with solar panel to improve the efficiency as well as reliability of system. For this purpose, the AC voltage of wind turbine is first converted into DC voltage and DC voltage from solar and wind is then given as input to the cascaded multilevel inverter. At the output of multilevel inverter, AC voltage is obtained. Using a 5-level cascaded H bridge multi level inverter, the DC output is changed into an AC output. The block diagram of proposed model is shown in figure 2.

## III. SIMULATION MODEL

MATLAB software is used to simulate the suggested model. Depending on the amount of solar panels connected in series and parallel, the KYOCERA SOLAR KC200GT module, which is used for solar, generates electricity up to 32 volts. This

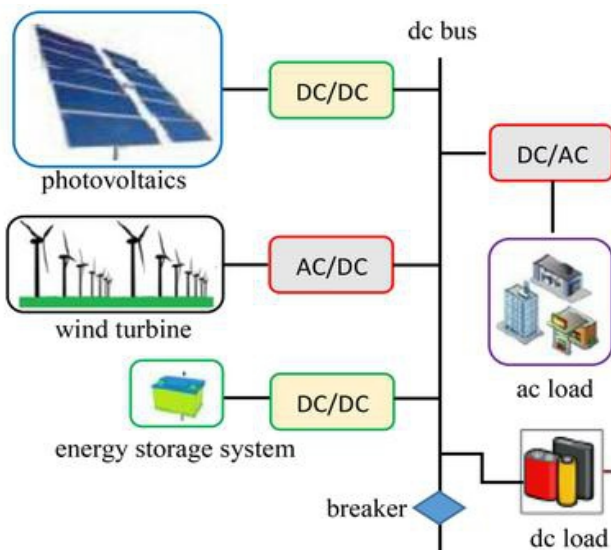

Fig. 1. Layout of microgrid

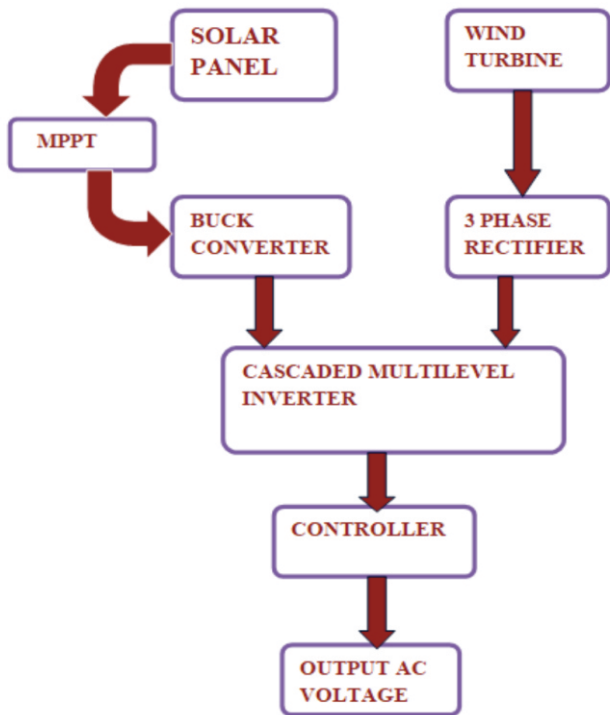

Fig. 2. Block diagram of the Model

voltage is reduced to the 24 volts by varying the inductance and capacitance values of buck converter accordingly. Wind turbines employ synchronous machines having permanent magnet. The three phase rectifier used in the wind turbine converts the AC electricity produced by it into DC voltage. For

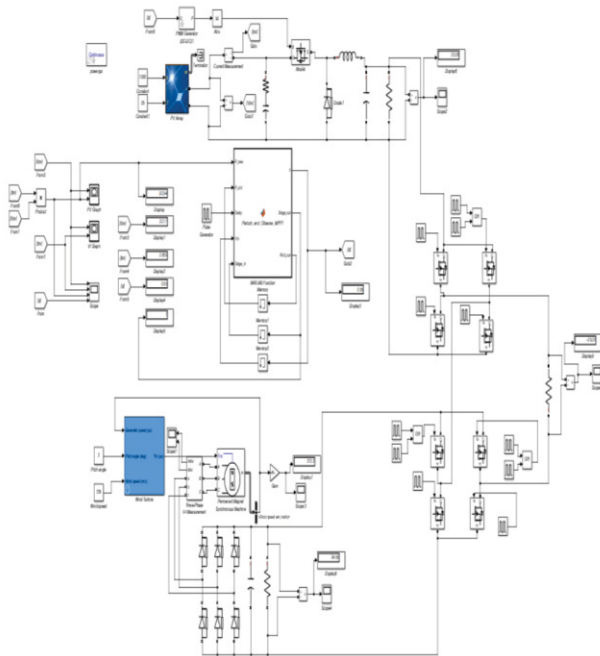

Fig. 3. MATLAB simulation circuit

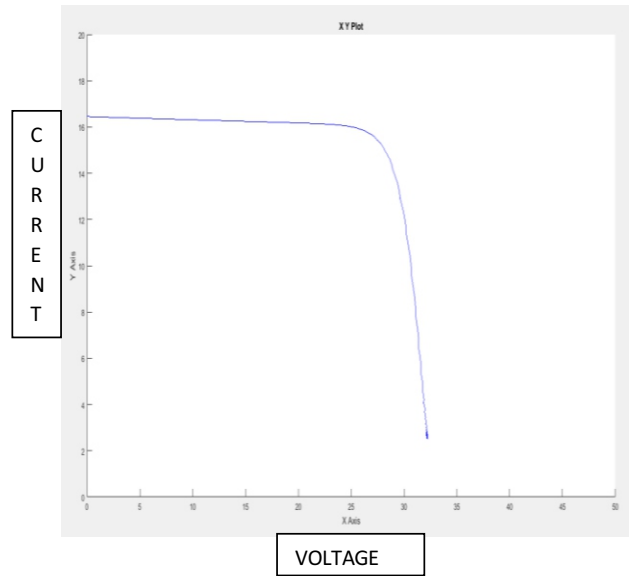

Fig. 4. The Graph between voltage and current

the output waveform to be smooth and the voltage ripples to be minimized, a capacitor is utilized in parallel with the rectifier. By altering pitch angle and wind speed, the wind turbine's output is set to 24 volts.

To convert the DC output power from solar panels and wind turbines into AC voltage, the model employs a multilevel inverter with five levels. Compared to other inverter topologies, a CBH inverter has fewer components. Capacitors and switches make up the device. The H bridge is the name for the circuit made out of switches and capacitors. There are eight MOSFET switches used in multilevel inverters. The switching sequence and the pulse width of these MOSFET switches is set so that a 5 level AC waveform is generated. MATLAB simulation circuit of the proposed model is shown in figure 3.

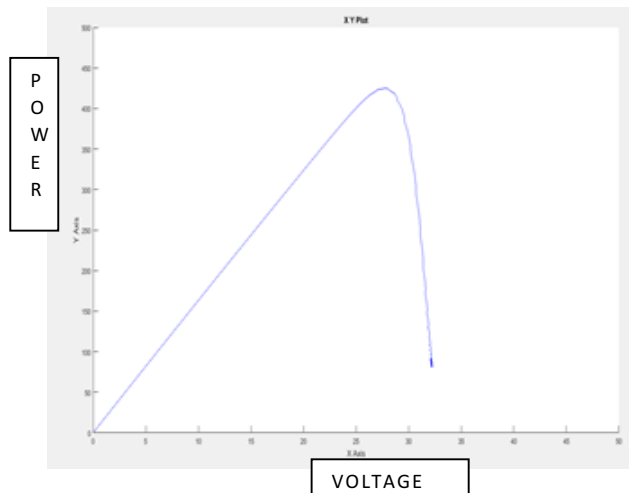

Fig. 5. The Graph between voltage and current

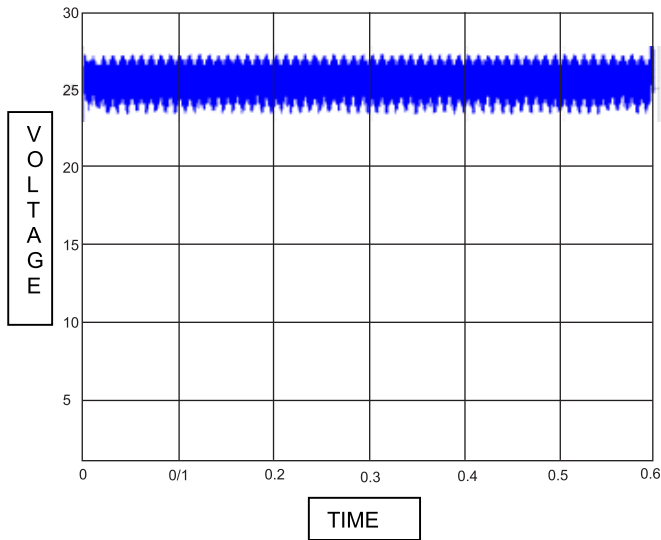

Fig. 6. The graph voltage and time obtained from the solar bucked output voltage.

#### IV. SIMULATION RESULTS

##### A) *Solar Panel Graphs*

The graph between voltage and current is shown in figure 4. The graph between power and voltage is shown in figure 5. The graph voltage and time obtained from the solar bucked output voltage is shown in figure 6.

##### B) *Wind Turbine waveforms*

The graph of AC output voltage obtained from wind turbine is shown in figure 7. The graph of DC output voltage obtained from wind turbine is shown in figure 8.

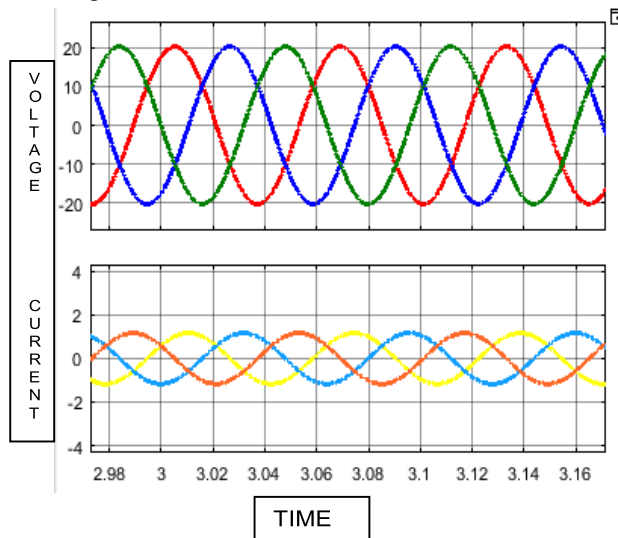

Fig. 7 The graph of AC output voltage

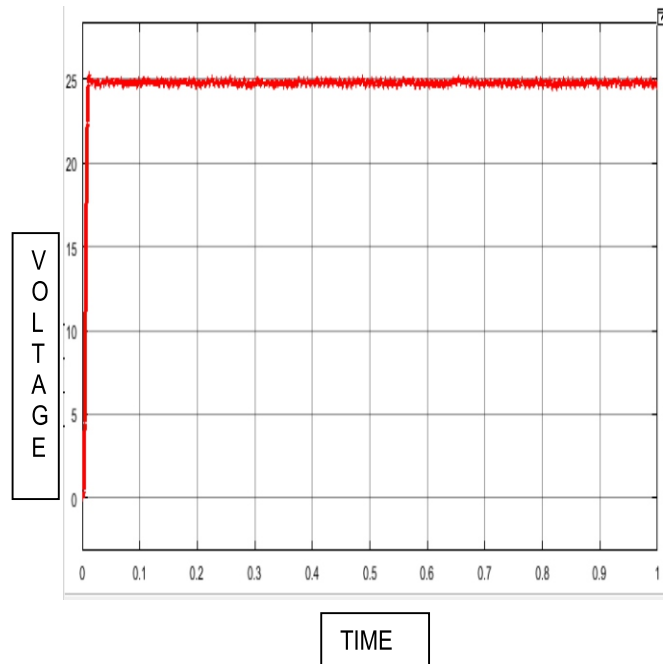

Fig. 8. The graph of DC output voltage.

##### C) *Multilevel Inverter waveform*

The output voltage of multilevel inverter is shown in figure 9.

#### V. IMPLEMENTATION OF HARDWARE

The hardware model of proposed project is designed using solar panel and DC batteries and thus the obtained results were analyzed. The hardware model comprised of solar panel, DC batteries, buck-boost converter, multilevel inverter and arduino. The dc voltage is generated from solar and batteries and CHB inverter used in the model converted this DC voltage into 5 level AC voltage at its output terminal. The harmonics are thus reduced through the use of multilevel inverter.

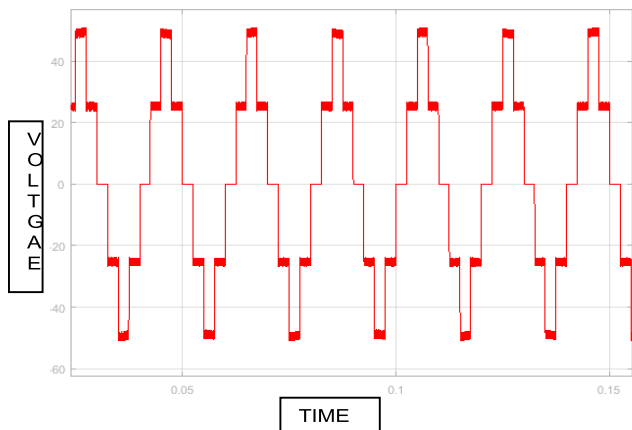

Fig. 9. The output voltage of multilevel inverter

**A) Solar Panel**

A solar panel of voltage 19 volts is used. It will generate maximum voltage when exposed to the bright sunlight. A built-in Mppt circuit is connected to the solar panel. This pv panel is capable of generating voltages upto 28 volts. The output voltage of this pv panel is maintained at 24 volts by using buck boost converter. The solar panel used is shown in figure 10.

**B) DC Batteries**

The DC batteries are used in replacement for wind turbine. For this purpose, four DC batteries are connected in series. A single battery is capable of generating 3.7 to 4.8 volts. The voltage of the batteries is added and stepped up to 24 volts with the help of buck-boost converter. However these batteries begin to discharge with the passage of time. So the batteries need to be charged through battery charger when required. The DC batteries used in the hardware model is shown in figure 11

**C) Buck-Boost Converter**

Two buck-boost converter circuits are used in the project. One is connected with solar panel and the other with DC batteries. The values of capacitance and inductance are so adjusted that they maintain the voltage level at 24 volts. A potentiometer is also connected in the circuit so that voltage can be increased to the desired value in case if enough sunlight is not available or batteries begin to discharge. The buck-boost converter used in the hardware model is shown in figure 11.

**D) CHB Inverter**

A cascaded H bridge multilevel inverter of 5 levels is used in the project to convert the DC voltages generated from pv panel and DC batteries into AC voltage. The circuit consists of eight MOSFETs that are assembled on the PCB board. The resistors of 1 k ohm are connected with the gate of MOSFET to limit the current. With each MOSFET, a heat sink is connected to protect the MOSFET from



Fig. 10. Solar Panel



Fig. 11. DC Batteries

overheating and burning. The gate signal of each MOSFET is generated through the Arduino UNO and 5 level voltage waveform is obtained at the output of inverter. The CHB inverter used in the hardware model is shown in figure 13

**E) Arduino**

The Arduino UNO is used to generate the gate pulse signals for the MOSFET used in multilevel inverter circuit. The pulse width technique is used for this purpose. The width of each pulse is adjusted so that the MOSFETs operate in such a way that 5 level voltage waveform is generated. The coding of Arduino UNO is done on the software named Arduino IDE. The arduino used in the hardware model is shown in figure 14.

**VI. HARDWARE MODEL**

The hardware model is the prototype of software simulation model. A solar plate is used that generate voltages upto 19 volts. This voltage is stepped up to 24 volts through buck boost converter connected to the solar panel. In place of wind turbine, 4 dc batteries each of 3.7 volts are connected in series. The voltage of these batteries is increased to 24 volts by buck boost converter. A 5 level cascaded H bridge multileve

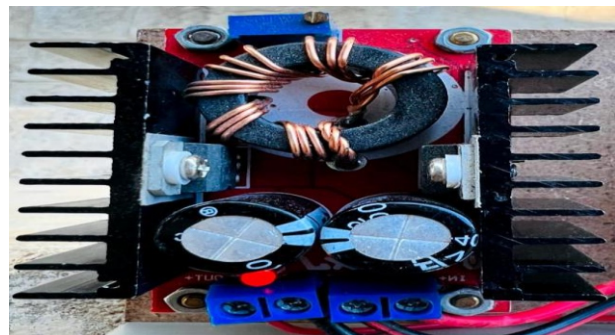

Figure 12. Back-boost converter



Fig. 13. CHB Inverter

inverter circuit is made on PCB using eight MOSFET switches. The DC voltage from solar panel and DC batteries is given at the input terminals of multilevel inverter. This multilevel inverter will convert the DC voltage of solar and batteries into pulsating AC voltage. The gate pulse of MOSFETs is generated with the help of Arduino UNO. At the output terminal of multilevel inverter, two level or five level voltage can be obtained. The hardware model of the project is shown in figure 15.

### VII. RESULTS

The 5 level output waveform is obtained from the scope and it is shown in figure 16. The harmonics spectrum of output waveform is shown in the figure 17.



Fig. 14. Arduino UNO

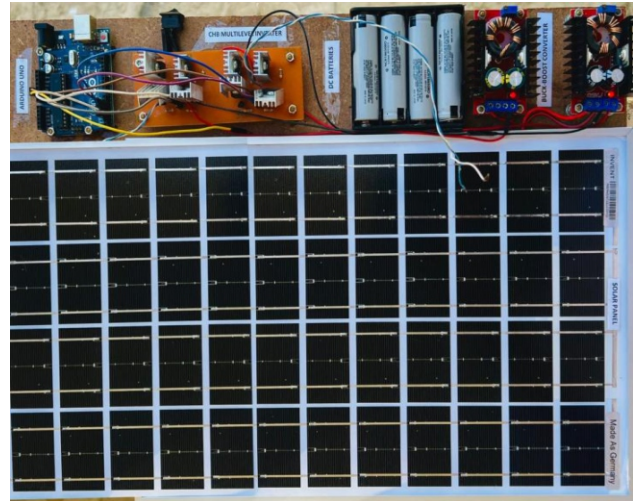

Fig. 15. Hardware Model

### VIII. CONCLUSION

In order to investigate alternative energy resources for mass production to satisfy the rising demand and to provide clean energy, this study is being conducted to evaluate the performance of the AC grid with renewable sources of energy. The system is more reliable as a result of the perfect cooperation of renewable resources like solar and wind energy. The quality of the potential for renewable energies heavily influences the hybrid power system configurations that can handle the desired load. The main benefit of a solar/wind/hybrid system is that it has higher system reliability when solar and wind energy are combined.

### REFERENCES

- [1] B. Ceran, "The concept of use of PV/WT/FC hybrid power generation system for smoothing the energy profile of the consumer," *Energy*, vol. 167, pp. 853-865, 2019.

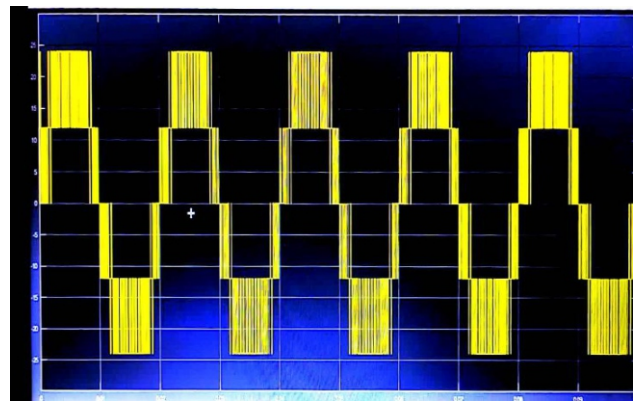

Fig. 16. Output waveform

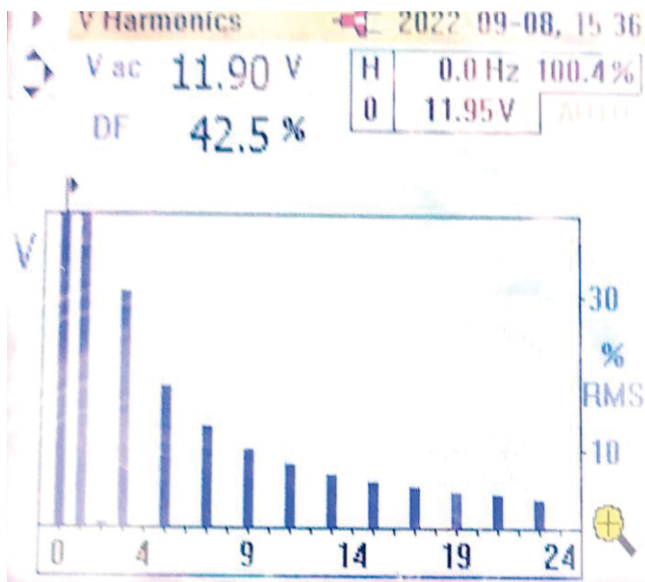

Fig. 17 Harmonics spectrum

- [2] K. N. Hasan, R. Preece, and J. V. Milanović, "Existing approaches and trends in uncertainty modelling and probabilistic stability analysis of power systems with renewable generation," *Renewable and Sustainable Energy Reviews*, vol. 101, pp. 168-180, 2019.
- [3] M. Asadi and K. PourHossein, "Wind and solar farms site selection using geographical information system (GIS), based on multi criteria decision making (MCDM) methods: A case-study for East-Azerbaijan," in *2019 Iranian Conference on Renewable Energy & Distributed Generation (ICREDG)*, 2019, pp. 1-6: IEEE.
- [4] A. S. Abdelrazik, F. Al-Sulaiman, R. Saidur, and R. Ben-Mansour, "A review on recent development for the design and packaging of hybrid photovoltaic/thermal (PV/T) solar systems," *Renewable and Sustainable Energy Reviews*, vol. 95, pp. 110-129, 2018.
- [5] K. Shivam, J.-C. Tzou, and S.-C. Wu, "Multi-step short-term wind speed prediction using a residual dilated causal convolutional network with nonlinear attention," *Energies*, vol. 13, no. 7, p. 1772, 2020.
- [6] R. Figaj, K. Sornek, S. Podlasek, and M. Żołądek, "Operation and sensitivity analysis of a micro-scale hybrid trigeneration system integrating a water steam cycle and wind turbine under different reference scenarios," *Energies*, vol. 13, no. 21, p. 5697, 2020.
- [7] D. B. Carvalho, E. C. Guardia, and J. W. M. Lima, "Technical-economic analysis of the insertion of PV power into a wind-solar hybrid system," *Solar Energy*, vol. 191, pp. 530-539, 2019.
- [8] C. Mokhtara, B. Negrou, N. Settou, B. Settou, and M. M. Samy, "Design optimization of off-grid Hybrid Renewable Energy Systems considering the effects of building energy performance and climate change: Case study of Algeria," *Energy*, vol. 219, p. 119605, 2021.
- [9] P. Chaudhary and M. Rizwan, "Energy management supporting high penetration of solar photovoltaic generation for smart grid using solar forecasts and pumped hydro storage system," *Renewable Energy*, vol. 118, pp. 928-946, 2018.
- [10] L. B. G. Campanhol, S. A. O. da Silva, A. A. de Oliveira, and V. D. Bacon, "Dynamic performance improvement of a grid-tied PV system using a feed-forward control loop acting on the NPC inverter currents," *IEEE Transactions on Industrial Electronics*, vol. 64, no. 3, pp. 2092-2101, 2016.
- [11] C. Shang, D. Srinivasan, and T. Reindl, "An improved particle swarm optimisation algorithm applied to battery sizing for stand-alone hybrid power systems," *International Journal of Electrical Power & Energy Systems*, vol. 74, pp. 104-117, 2016.
- [12] J. Li et al., "How to make better use of intermittent and variable energy? A review of wind and photovoltaic power consumption in China," *Renewable and Sustainable Energy Reviews*, vol. 137, p. 110626, 2021.
- [13] M. Rezkallah, S. Sharma, A. Chandra, and B. Singh, "Implementation and control of small-scale hybrid standalone power generation system employing wind and solar energy," in *2016 IEEE Industry Applications Society Annual Meeting*, 2016, pp. 1-7: IEEE.
- [14] S. Z. Hassan, H. Li, T. Kamal, and M. Awais, "Stand-alone/grid-tied wind power system with battery/supercapacitor hybrid energy storage," in *2015 International Conference on Emerging Technologies (ICET)*, 2015, pp. 1-6: IEEE.
- [15] T. Dragičević, X. Lu, J. C. Vasquez, and J. M. Guerrero, "DC microgrids Part I: A review of control strategies and stabilization techniques," *IEEE Transactions on power electronics*, vol. 31, no. 7, pp. 4876-4891, 2015.
- [16] N. Ghorbani, A. Kasaieian, A. Toopshekan, L. Bahrami, and A. Maghami, "Optimizing a hybrid wind-PV-battery system using GA-PSO and MOPSO for reducing cost and increasing reliability," *Energy*, vol. 154, pp. 581-591, 2018.
- [17] G. Shahgholian, "Analysis and simulation of dynamic performance for DFIG-based wind farm connected to a distribution system," *Energy Equipment and Systems*, vol. 6, no. 2, pp. 117-130, 2018.